



**Facility Study
For
Generator Interconnection
Request
GEN-2013-002**

*SPP Generator
Interconnection Studies*

(#GEN-2013-002)

March 2015

Revision History

Date	Author	Change Description
12/17/2013	SPP	Facility Study Report Issued
11/25/2014	SPP	Facility Study Revised and Report updated for latest DISIS-2013-001-4 restudy results
2/18/2015	SPP	Incorporates updated estimates from LES and Nebraska Public Power District
3/4/2015	SPP	Edits and updates for corrections

Summary

Lincoln Electric System (LES) and Nebraska Public Power District (NPPD) performed a detailed Facility Study at the request of Southwest Power Pool (SPP) for Generation Interconnection request GEN-2013-002 (50.6 MW/Wind) located in Lancaster and Gage Counties, Nebraska. The LES analysis is located in Appendix A. The NPPD analysis is located in Appendix B. SPP has proposed the in-service date will be after the assigned Transmission Owner Interconnection Facilities and Non-Shared Network Upgrades are completed. Full Interconnection Service will require the Network Upgrades listed in the “Other Network Upgrades” section. The request for interconnection was placed with SPP in accordance with SPP’s Open Access Transmission Tariff, which covers new generation interconnections on SPP’s transmission system.

Phases of Interconnection Service

It is not expected that interconnection service will require phases however, interconnection service will not be available until all interconnection facilities and network upgrades can be placed in service.

Interconnection Customer Interconnection Facilities

The Interconnection Customer will be responsible for all of the transmission facilities connecting the customer owned substation to the Point of Interconnection (POI), at a new Lincoln Electric System (LES) owned 115kV substation. The new LES 115kV substation will be a tap on the Sheldon Station – Folsom 115kV circuit. The Interconnection Customer will also be responsible for any equipment located at the Customer substation necessary to maintain a power factor of 0.95 lagging to 0.95 leading at the POI.

Transmission Owner Interconnection Facilities and Non-Shared Network Upgrades

To allow interconnection the Transmission Owner will need construct a three breaker ring bus along with associated terminal equipment that is acceptable for the addition of the Interconnection Customer’s Interconnection Facilities. LES has proposed a lead time of approximately twenty-four (24) months for the completion of the Interconnection Facilities and Non-Shared Network Upgrades. NPPD has identified Non-Shared Network Upgrades of protective relays and communication equipment replacement at Sheldon 115kV for the addition of this request. At this time GEN-2013-002 is responsible for \$3,138,685 of LES Transmission Owner Interconnection Facilities and Non-Shared Network Upgrades. This cost does not include the cost of the site for the substation, which will be provided by the Interconnection Customer and turned over to LES. At this time GEN-2013-002 is also responsible for \$92,000 of NPPD Non-Shared Network Upgrades. GEN-2013-002 is responsible for Transmission Owner Interconnection Facilities and Non-Shared Network Upgrade with total estimated costs of \$3,230,685. Figure 1 is a one-line diagram for the GEN-2013-002 interconnection configuration.

Figure 1: Interconnection Configuration for GEN-2013-002

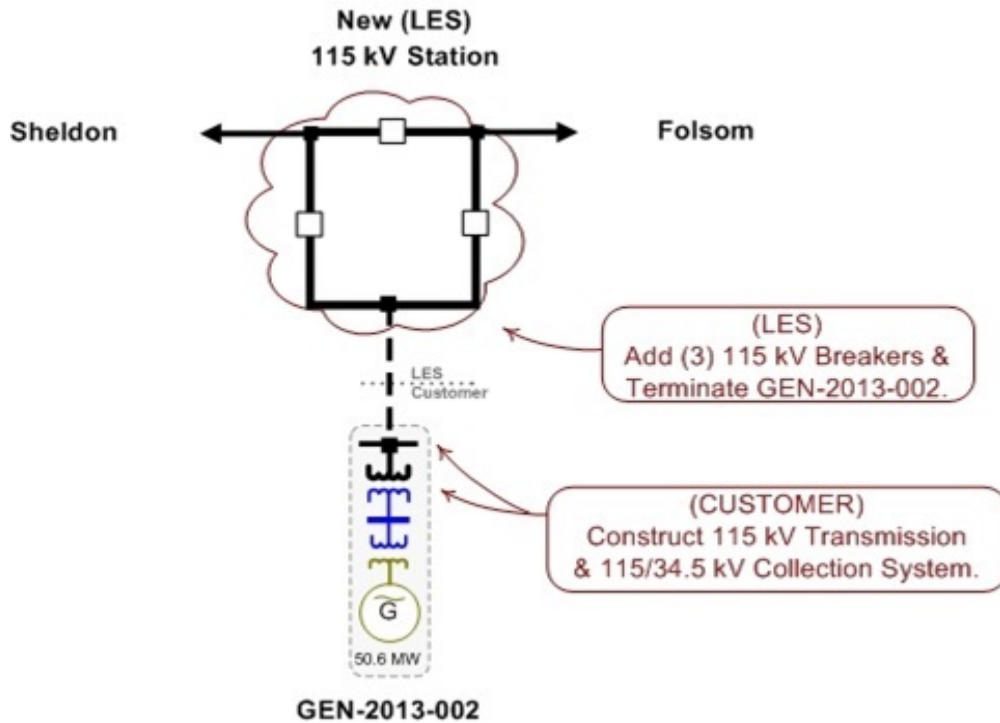

Shared Network Upgrades

The Interconnection Customer was studied within the DISIS-2013-001 Impact Study. At this time, the Interconnection Customer is allocated \$0 for Shared Network Upgrades. If higher queued interconnection customers withdraw from the queue, suspend or terminate their GIA, restudies will have to be conducted to determine the Interconnection Customers' allocation of Shared Network Upgrades. All studies have been conducted on the basis of higher queued interconnection requests and the upgrades associated with those higher queued interconnection requests being placed in service. At this time, the Interconnection Customer is allocated the following cost for Shared Network Upgrade:

Share Network Upgrade Description	Allocated Cost	Total Cost
None	\$0.00	\$0.00
Total	\$0.00	

Other Network Upgrades

At this time there are no Other Network Upgrades that are currently the cost responsibility of the Customer.

Depending upon the status of higher or equally queued customers, the Interconnection Customer's in-service date is at risk of being delayed or their Interconnection Service is at risk of being reduced until the in-service date of these Other Network Upgrades.

Conclusion

Interconnection Service for GEN-2013-002 will be delayed until the Transmission Owner Interconnection Facilities and Non-Shared Network Upgrades are constructed. The Interconnection Customer is responsible for \$3,138,685 of Transmission Owner Interconnection Facilities and Non-Shared Network Upgrades, which does not include the cost of the site. The Interconnection Customer is also allocated \$92,000 for other transmission owning entity (Nebraska Public Power District) Network Upgrades. At this time, the Interconnection Customer is allocated \$0 for Shared Network Upgrades. After all Interconnection Facilities and Network Upgrades have been placed into service, Interconnection Service for 50.6 MW as requested by GEN-2013-002 can be allowed.

At this time the total allocation of costs assigned to GEN-2013-002 for Interconnection Service are estimated at \$3,230,685.

APPENDIX A

LES Facility Study



Lincoln Electric System

February, 2015

Generation Interconnection Facility
Study (Revised)

For

Generation Interconnection Request
GEN-2013-002

50.6 MW Wind Generation Facilities

Prepared by:
Resource & Transmission Planning Department
Lincoln Electric System
1040 O Street
Lincoln, NE 68501-0869
p: 402.475.4211
www.les.com

Table of Contents

Executive Summary	3
Introduction	4
Interconnected Facilities	5
Schedule	5
Steady-State Evaluation	6
Stability Analysis.....	6
Short Circuit Fault Duty Evaluation	6

Executive Summary

At the request of the Southwest Power Pool (SPP), Lincoln Electric System (LES) performed the following Facility Study to satisfy the Facility Study Agreement executed by the requesting Customer for SPP Generation Interconnection request Gen-2013-002. The request for interconnection was placed with SPP in accordance with SPP's Open Access Transmission Tariff, which covers new generation interconnections on SPP's transmission system.

The facilities needed for the generation interconnection consist of adding three 115-kV breakers in a new substation. The total cost for LES to construct the new 115-kV substation in a three terminal ring bus configuration, including a terminal for the Customer's wind farm interconnection, is estimated at \$3,138,685. This estimate does not include the cost of land, which is to be provided by the Interconnection Customer.

SPP's Definitive Interconnection System Impact Study (DISIS) did not identify any short circuit, stability, or power flow issues that required further study.

Introduction

The Southwest Power Pool has requested a Facility Study for the purpose of interconnecting 50.6 MW of wind generation to the portion of the Bulk Electric System owned by Lincoln Electric System (LES). The proposed 115-kV point of interconnection will be at a new substation connected to the 16-mile, Sheldon to Folsom & Pleasant Hill 115-kV transmission line (LN-1197). This substation will be owned by LES. The Customer's wind turbines would be located in Lancaster and Gage Counties, Nebraska.

Interconnected Facilities

The requirements for interconnection of the Customer's generation facilities (Gen-2013-002) consist of constructing a new 115-kV substation configured in a three breaker ring bus. It is assumed that the substation will be located in close proximity to the LES owned transmission line LN-1197, and therefore, there would be minimal 115-kV line right-of-way and construction costs associated with the project. This 115-kV substation shall be constructed and maintained by LES.

The total cost for LES to construct and interconnect the new 115-kV substation to LN-1197 is currently estimated at \$3,138,685. This estimate does not include the cost of land, which is to be provided by the Interconnection Customer. For a detailed cost breakdown, see the related SPP Standardized Cost Estimate Reporting Template (SCERT). The Customer is responsible for all costs necessary to interconnect their project to the newly constructed LES owned substation, and these costs are not included in the estimated costs. Should the project be delayed, LES may need to revise the cost estimate to reflect variances in the price of labor and materials.

This Facility Study does not address the availability of transmission service necessary to deliver the Customer generation to any specific point inside or outside the Southwest Power Pool (SPP) transmission system. The Customer must request firm transmission service under the SPP Open Access Transmission Tariff to determine Network Upgrades or new construction required to provide transmission service under the SPP OATT.

Schedule

The Customer has requested a commercial operation date of either December, 2016 or December, 2017, and LES projects a lead time of roughly 12 months to construct and commission this facility. The LES schedule to construct and commission this facility does not include procurement of the land by the Interconnection Customer.

Should the project be delayed, LES may need to revise the lead time estimate to reflect variances in work load and other construction projects.

Steady-State Evaluation

Power flow analysis has indicated, for the power flow cases that LES studied, it is possible to interconnect the Customer's generation facilities with its nameplate capacity of 50.6 MW to a new LES owned substation that is connected to its transmission line LN-1197. There are additional requirements for interconnection that are described in the LES document entitled "Requirements for Transmission System Interconnection to Generation, Transmission and End-User Facilities."

Stability Analysis

The Stability Analysis, performed by SPP, determined that there was no wind turbine tripping that occurred from interconnecting the wind farm at 100% of nameplate capacity, and no voltages were observed to exceed 1.20 pu or fall below 0.7 pu at any time after the fault was cleared.

Short Circuit Fault Duty Evaluation

It is standard practice for LES to recommend replacing a circuit breaker when the current through the breaker for a fault exceeds 100% of its interrupting rating. For this generator interconnection, LES determined that no existing LES breakers were found to exceed their interrupting capability after addition of the Customer's 50.6 MW generation facilities. Therefore, there is no short circuit upgrade costs associated with the Gen-2013-002 interconnection.

APPENDIX B

NPPD Facility Study

Upgrades on Nebraska Public Power District attributable to GEN-2013-002

The proposed interconnection of the GEN-2013-002 Interconnection Request proposes a new substation on a tie line between Lincoln Electric System and Nebraska Public Power District (NPPD), referred to as Line 1197. NPPD has responded to a request from SPP regarding impacts to NPPD for the Interconnection Request.

NPPD Sheldon 115kV substation – The existing relays at Sheldon substation protecting the Folsom 115kV transmission line will need to be replaced to accommodate generation interconnected on the line.

Protection and Control Equipment - The existing Schweitzer SEL-421 relay in Panel 1 for Line 1197 will be removed from service. A new Schweitzer SEL-411L relay will be installed. The protection scheme will require a fiber connection to the new LES substation and proposed generating facility. The work includes engineering, installation, checkout, and commissioning.

- Estimated Cost - \$60,000

Telecommunications Equipment – Install underground fiber cable from the transmission line to the Sheldon substation control building, fiber patch panels, and electronics. This work does not include electronics for LES to install circuits placed into a ring system. Line 1197 presently includes OPGW fiber. The fiber would be separated at the new LES substation and the fiber will be run underground to the LES substation control house. A patch panel will be used to connect the fiber at the LES substation control house.

- Estimated Cost - \$32,000

Total NPPD Costs - \$92,000